

INDEX	NUMBER	DATE	VISUM	NICHT VERMASSTE RADIIEN NOT DIMENSIONED RADIUS	R5	MATERIAL	ERP NUMBER
-	-	-	-	KANTEN GEBROCHEN SHARP EDGES REMOVED	0.2...0.4	GEW./MASS	ERP RAW NR.
-	-	-	-	DREHMOMENT NACH TORQUE ACCORDING TO	AAW_0002	209.209 kg	UNLESS OTHERWISE SPECIFIED DIMENSIONS EXPRESSED IN METRIC
-	-	-	-	GENERAL TOLERANCES / ALLGEMEINTOLERANZEN		FINISH ACCORDING	APPROVALS
-	-	-	-	ISO 2768 - m L		TO AAW_0005	DATE
-	-	-	-	WELD SYMBOLS / SCHWEISSYMBOLS			raj
-	-	-	-	EN 22553			20.06.24
-	-	-	-				CHECKED & RELEASED
-	-	-	-				-

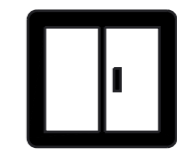

Almatec AG  
Industriestrasse 12  
CH-6170 Schüpfheim  
Switzerland

ALM-ANK10010045  
1000H x 1000W x 450D  
DOUBLE WALL ELECTRICAL CABINET

SIZE	ALMATEC IDENT NUMBER	REV
A3	1585625	-
SCALE	RELEASE STATUS	SHEET
1:12	Wird bearbeitet	1/3

THIS DRAWING AND THE DESIGN SHOWN HERE ON ARE THE EXCLUSIVE PROPERTY OF ALMATEC SWITZERLAND. ITS CONTENTS CANNOT BE COPIED, COMMUNICATED OR REPRODUCED IN ANY FORM, FOR ANY PURPOSE, WITHOUT PRIOR SPECIFIC WRITTEN CONSENT FROM ALMATEC SWITZERLAND.  
DIESE ZEICHNUNG UND IHR INHALT STEHEN UNTER DEM ALLEINIGEN RECHT DER FIRMA ALMATEC SWITZERLAND. DIE ZEICHNUNG UND IHR INHALT DÜRFEN IN KEINER FORM KOPIERT, WEITERGEGEBEN, ODER REPRODUZIERT WERDEN, OHNE DIE SCHRIFTLICHE ZUSTIMMUNG DER FIRMA ALMATEC SWITZERLAND.

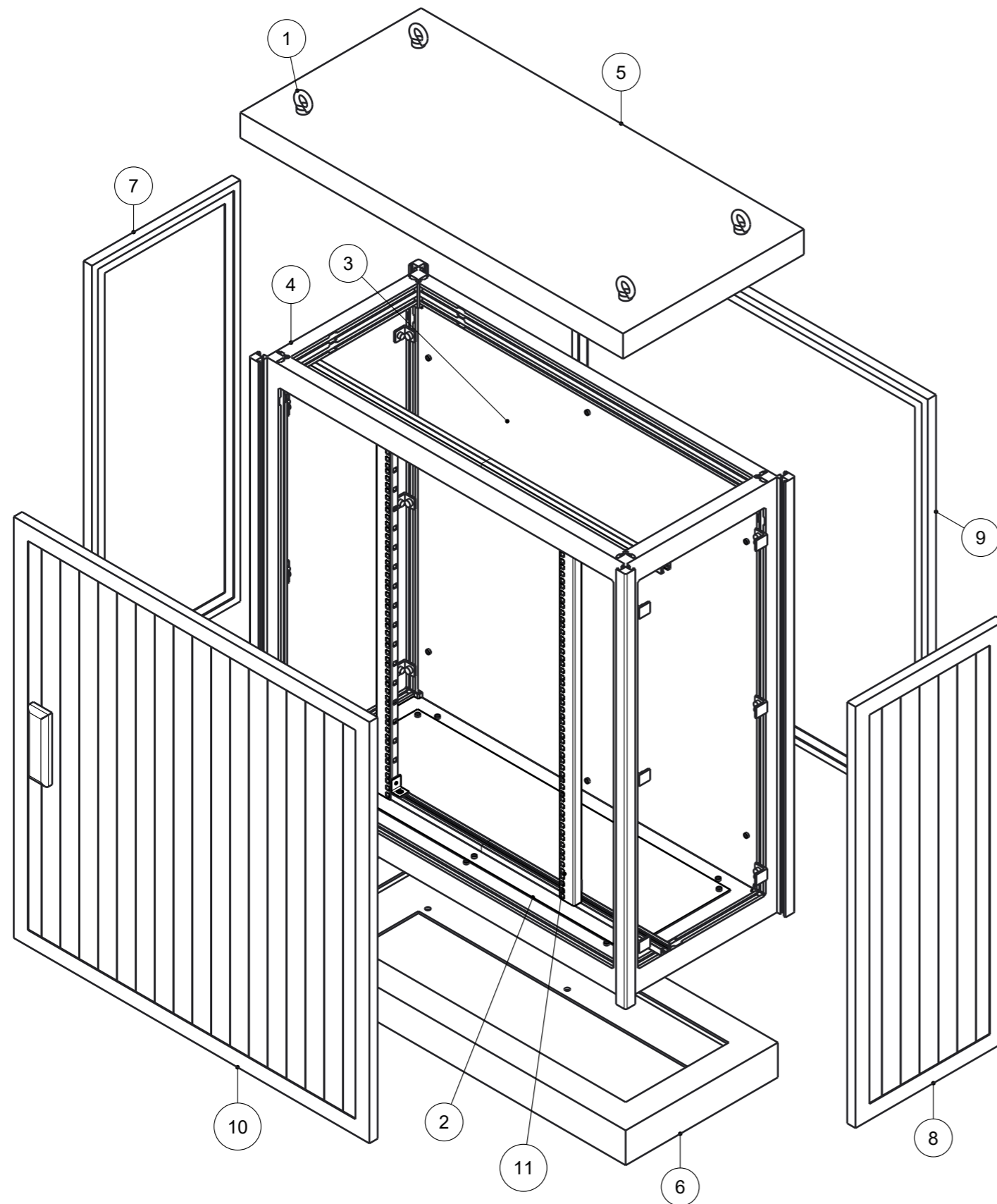

ITEM NO	Part number	QTY Stk.	Description Benennung	Weight Gewicht kg / Part
1	012877	4	Ringschraube M10	0.102
2	1585627	1	ANK Bodenblech aufgesetzt 1000x450 mit Flanschplatte	3.250
3	1585630	1	ANK Montageplatte 1000x1000	6.798
4	1585634	1	Dummy ANK Ständer	29.724
5	1585635	1	Dummy ANK Flachdach 58 1000x450	46.118
6	1585636	1	Dummy ANK Sockel 1000x80x450	7.821
7	1585637	1	Dummy ANK Seitenwand links 1000x450	16.820
8	1585638	1	Dummy ANK Seitenwand rechts 1000x450	16.820
9	1585639	1	Dummy ANK Rückwand 1000x1000	38.964
10	1585640	1	Dummy ANK Türe 1-flüglig	39.385
11	1585915	1	19" Einbau	2.694

INDEX	NUMBER	DATE	VISUM	NICHT VERMASSTE RADIIEN NOT DIMENSIONED RADIUS R5	MATERIAL	ERP NUMBER	-		<b>ALM-ANK10010045</b> 1000H x 1000W x 450D DOUBLE WALL ELECTRICAL CABINET		
-	-	-	-	KANTEN GEBROCHEN SHARP EDGES REMOVED 0.2...0.4	GEW./MASS 209.209 kg	ERP RAW NR.	-				
-	-	-	-	DREHMOMENT NACH TORQUE ACCORDING TO AAW_0002	FINISH ACCORDING TO AAW_0005	UNLESS OTHERWISE SPECIFIED DIMENSIONS EXPRESSED IN METRIC	APPROVALS	DATE	SIZE	ALMATEC IDENT NUMBER	REV
-	-	-	-	GENERAL TOLERANCES / ALLGEMEINTOLERANZEN	TO AAW_0005	DRAWN	raja	20.06.24	A3	1585625	-
-	-	-	-	WELD SYMBOLS / SCHWEISSYMBOLS	EN 22553	CHECKED & RELEASED	-	-	SCALE	RELEASE STATUS	SHEET
-	-	-	-						1:10	Wird bearbeitet	2/3



THIS DRAWING AND THE DESIGN SHOWN HERE ON ARE THE EXCLUSIVE PROPERTY OF ALMATEC SWITZERLAND. ITS CONTENTS CANNOT BE COPIED, COMMUNICATED OR REPRODUCED IN ANY FORM, FOR ANY PURPOSE, WITHOUT PRIOR SPECIFIC WRITTEN CONSENT FROM ALMATEC SWITZERLAND.  
 DIESE ZEICHNUNG UND IHR INHALT STEHEN UNTER DEM ALLEINIGEN RECHT DER FIRMA ALMATEC SWITZERLAND. DIE ZEICHNUNG UND IHR INHALT DÜRFEN IN KEINER FORM KOPIERT, WEITERGEGEBEN, ODER REPRODUZIERT WERDEN, OHNE DIE SCHRIFTLICHE ZUSTIMMUNG DER FIRMA ALMATEC SWITZERLAND.

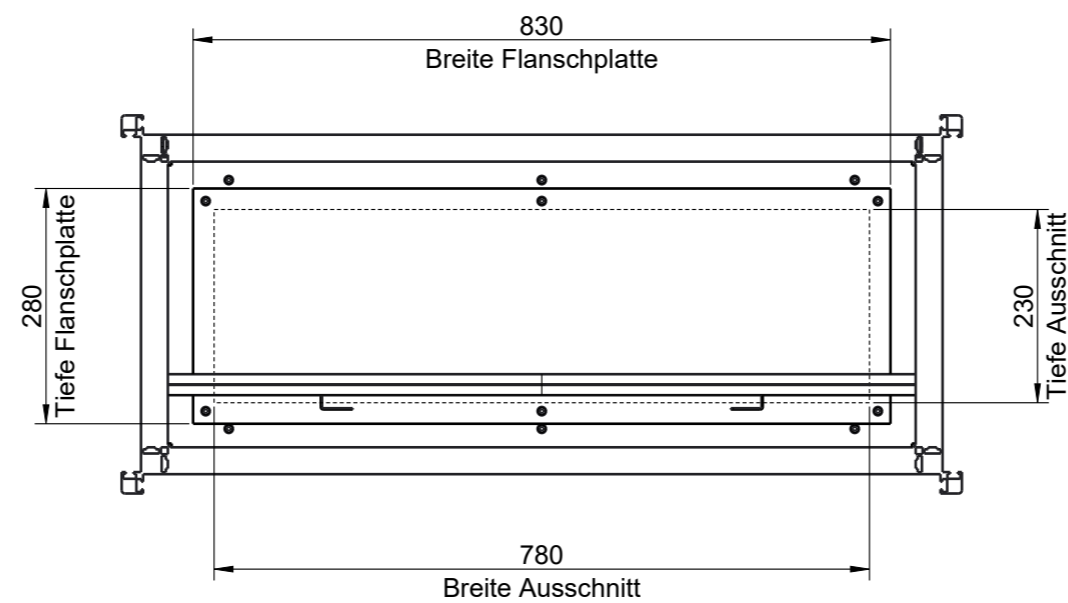
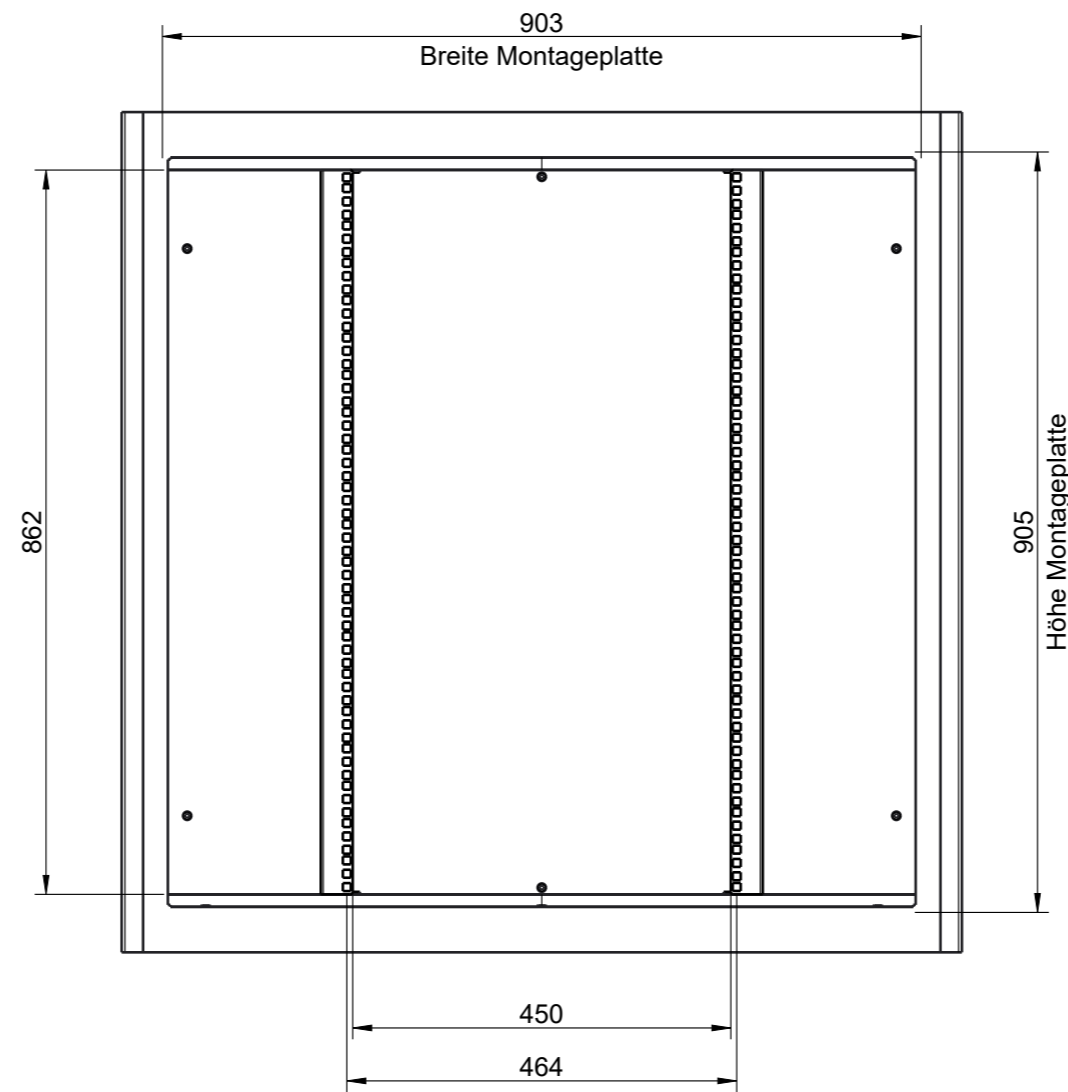

INDEX	NUMBER	DATE	VISUM	NICHT VERMASSTE RADIIEN NOT DIMENSIONED RADIUS	R5	MATERIAL	ERP NUMBER		
-	-	-	-	KANTEN GEBROCHEN SHARP EDGES REMOVED	0.2...0.4		ERP RAW NR.		
-	-	-	-	DREHMOMENT NACH TORQUE ACCORDING TO	AAW_0002	GEW./MASS 209.209 kg	UNLESS OTHERWISE SPECIFIED DIMENSIONS EXPRESSED IN METRIC		
-	-	-	-	GENERAL TOLERANCES / ALLGEMEINTOLERANZEN		FINISH ACCORDING TO AAW_0005	APPROVALS	DATE	
-	-	-	-	ISO 2768 - m L			DRAWN	20.06.24	
-	-	-	-	WELD SYMBOLS / SCHWEISSSYMBOLS			CHECKED & RELEASED		
-	-	-	-	EN 22553					

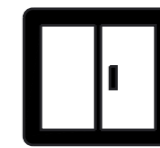

Almatec AG  
Industriestrasse 12  
CH-6170 Schüpfheim  
Switzerland

ALM-ANK10010045  
1000H x 1000W x 450D  
DOUBLE WALL ELECTRICAL CABINET

SIZE	ALMATEC IDENT NUMBER	REV
A3	1585625	-
SCALE	RELEASE STATUS	SHEET
1:9	Wird bearbeitet	3/3