

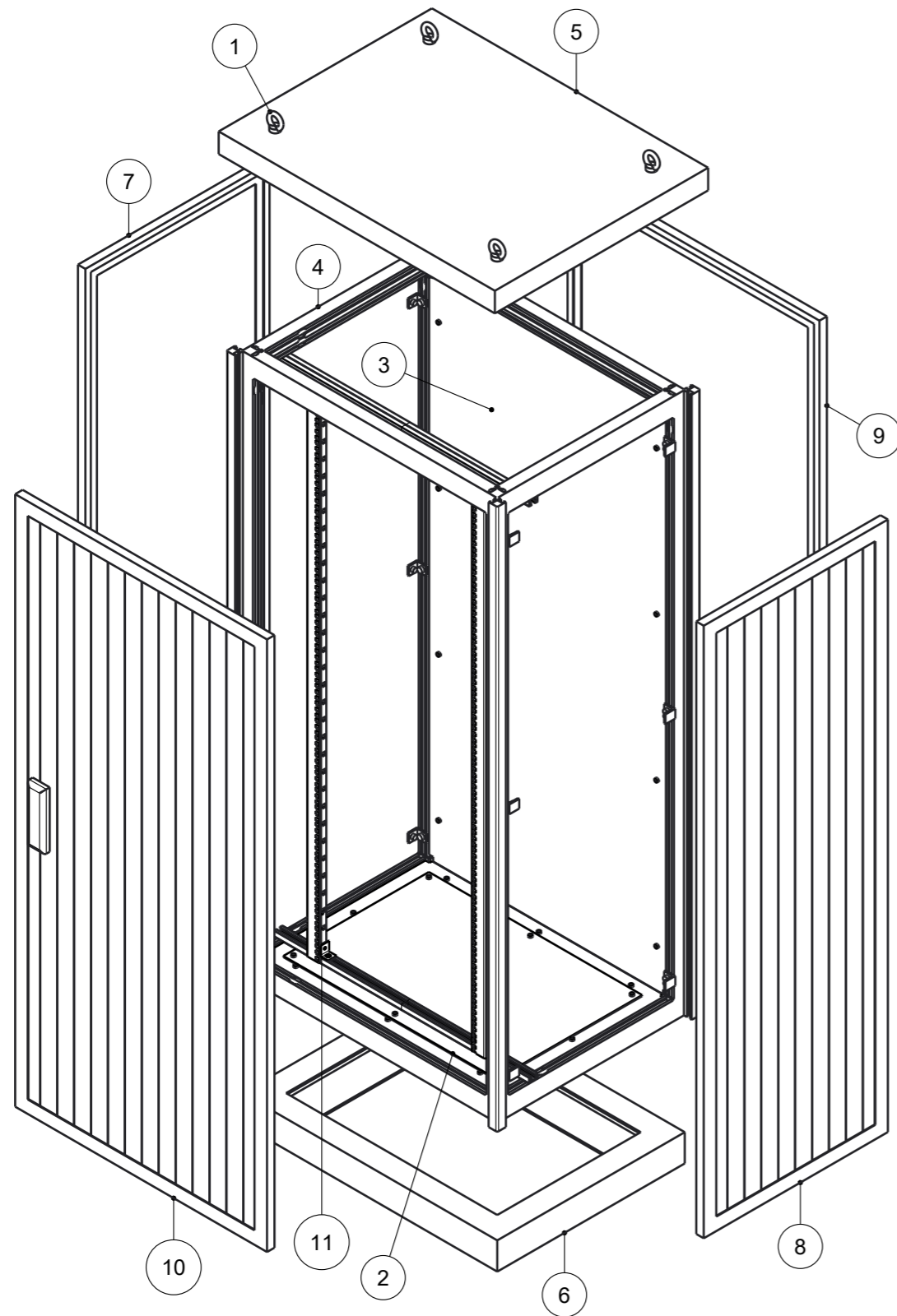

| INDEX | NUMBER | DATE | VISUM | NICHT VERMASSTE RADIIEN NOT DIMENSIONED RADIUS | R5 | MATERIAL | ERP NUMBER | | |
|-------|--------|------|-------|---|-----------|---------------------------------|--|-----------|----------|
| - | - | - | - | KANTEN GEBROCHEN SHARP EDGES REMOVED | 0.2...0.4 | | ERP RAW NR. | | |
| - | - | - | - | DREHMOMENT NACH TORQUE ACCORDING TO | AAW_0002 | GEW./MASS 282.278 kg | UNLESS OTHERWISE SPECIFIED DIMENSIONS EXPRESSED IN METRIC | | |
| - | - | - | - | GENERAL TOLERANCES / ALLGEMEINTOLERANZEN | | FINISH ACCORDING TO AAW_0005 | DRAWN | APPROVALS | DATE |
| - | - | - | - | ISO 2768 - m L | | | raja | | 20.06.24 |
| - | - | - | - | WELD SYMBOLS / SCHWEISSSYMBOLS | | | CHECKED & RELEASED | | |
| - | - | - | - | EN 22553 | | | | | |

| | | | | | |
|---|------|----------------------|---|-------|-----|
|  | | | ALM-ANK1608060 1600H x 800W x 600D DOUBLE WALL ELECTRICAL CABINET | | |
| SIZE | A3 | ALMATEC IDENT NUMBER | 1585524 | REV | - |
| SCALE | 1:15 | RELEASE STATUS | Wird bearbeitet | SHEET | 1/3 |

THIS DRAWING AND THE DESIGN SHOWN HERE ON ARE THE EXCLUSIVE PROPERTY OF ALMATEC SWITZERLAND. ITS CONTENTS CANNOT BE COPIED, COMMUNICATED OR REPRODUCED IN ANY FORM, FOR ANY PURPOSE, WITHOUT PRIOR SPECIFIC WRITTEN CONSENT FROM ALMATEC SWITZERLAND.
 DIESE ZEICHNUNG UND IHR INHALT STEHEN UNTER DEM ALLEINIGEN RECHT DER FIRMA ALMATEC SWITZERLAND. DIE ZEICHNUNG UND IHR INHALT DÜRFEN IN KEINER FORM KOPIERT, WEITERGEGEBEN, ODER REPRODUZIERT WERDEN, OHNE DIE SCHRIFTLICHE ZUSTIMMUNG DER FIRMA ALMATEC SWITZERLAND.





| ITEM NO | Part number | QTY Stk. | Description Benennung | Weight Gewicht kg / Part |
|---------|-------------|----------|---|--------------------------|
| 1 | 012877 | 4 | Ringschraube M10 | 0.102 |
| 2 | 1585526 | 1 | ANK Bodenblech aufgesetzt 800x600 mit Flanschplatte | 3.586 |
| 3 | 1585529 | 1 | ANK Montageplatte 800x1600 | 8.810 |
| 4 | 1585533 | 1 | Dummy ANK Ständer | 36.280 |
| 5 | 1585534 | 1 | Dummy ANK Flachdach 58 800x600 | 48.553 |
| 6 | 1585535 | 1 | Dummy ANK Sockel 800x80x600 | 7.506 |
| 7 | 1585536 | 1 | Dummy ANK Seitenwand links 1600x600 | 36.713 |
| 8 | 1585537 | 1 | Dummy ANK Seitenwand rechts 1600x600 | 36.713 |
| 9 | 1585538 | 1 | Dummy ANK Rückwand 800x1600 | 49.625 |
| 10 | 1585539 | 1 | Dummy ANK Türe 1-flüglig | 50.047 |
| 11 | 1585877 | 1 | 19" Einbau | 3.669 |

| INDEX | NUMBER | DATE | VISUM | NICHT VERMASSTE RADIIEN NOT DIMENSIONED RADIUS R5 | MATERIAL | ERP NUMBER | UNLESS OTHERWISE SPECIFIED DIMENSIONS EXPRESSED IN METRIC | |  Almatec AG Industriestrasse 12 CH-6170 Schüpfheim Switzerland | SIZE | ALMATEC IDENT NUMBER | REV |
|-------|--------|------|-------|--|---------------------------------|-------------|--|--|---|-------|----------------------|---------|
| - | - | - | - | KANTEN GEBROCHEN SHARP EDGES REMOVED 0.2...0.4 | GEW./MASS 282.278 kg | ERP RAW NR. | APPROVALS | | | DATE | A3 | 1585524 |
| - | - | - | - | DREHMOMENT NACH TORQUE ACCORDING TO AAW_0002 | FINISH ACCORDING TO AAW_0005 | | DRAWN | | 20.06.24 | SCALE | RELEASE STATUS | SHEET |
| - | - | - | - | GENERAL TOLERANCES / ALLGEMEINTOLERANZEN ISO 2768 - m L | | | CHECKED & RELEASED | | - | 1:13 | Wird bearbeitet | 2/3 |
| - | - | - | - | WELD SYMBOLS / SCHWEISSYMBOLLE EN 22553 | | | | | | | | |

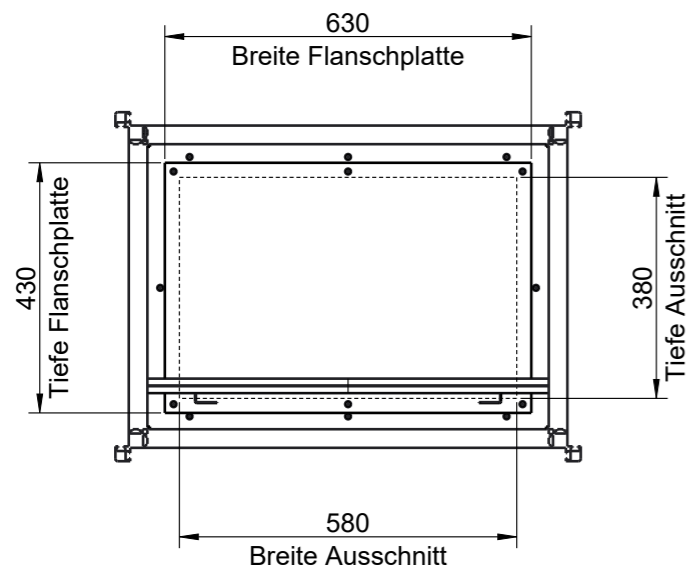
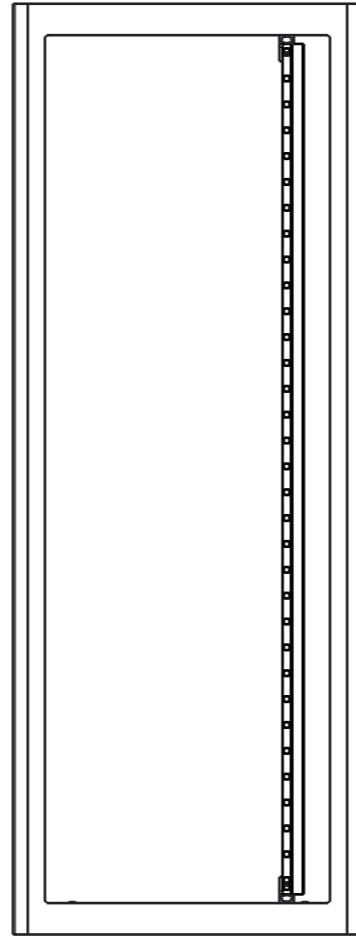
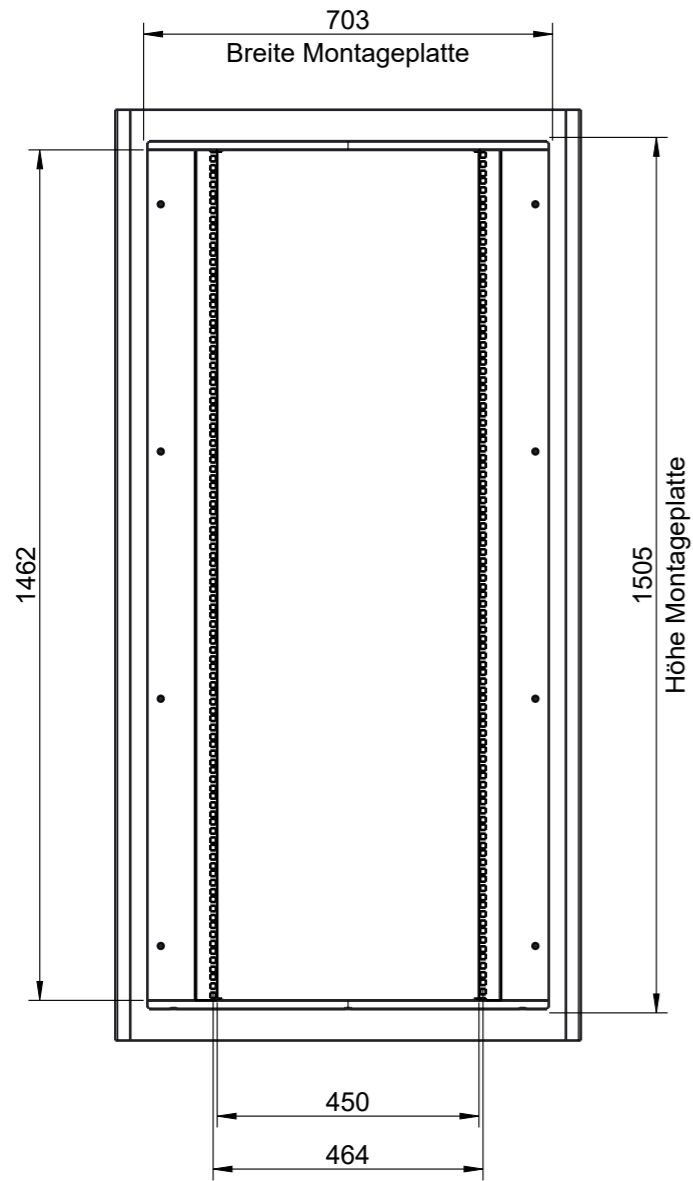
THIS DRAWING AND THE DESIGN SHOWN HERE ON ARE THE EXCLUSIVE PROPERTY OF ALMATEC SWITZERLAND. ITS CONTENTS CANNOT BE COPIED, COMMUNICATED OR REPRODUCED IN ANY FORM, FOR ANY PURPOSE, WITHOUT PRIOR SPECIFIC WRITTEN CONSENT FROM ALMATEC SWITZERLAND.
 DIESE ZEICHNUNG UND IHR INHALT STEHEN UNTER DEM ALLEINIGEN RECHT DER FIRMA ALMATEC SWITZERLAND. DIE ZEICHNUNG UND IHR INHALT DÜRFEN IN KEINER FORM KOPIERT, WEITERGEGEBEN, ODER REPRODUZIERT WERDEN, OHNE DIE SCHRIFTLICHE ZUSTIMMUNG DER FIRMA ALMATEC SWITZERLAND.



| | | | | | | | | | | |
|-------|--------|------|-------|--|---|--|----------|---|---|----------------------|
| INDEX | NUMBER | DATE | VISUM | NICHT VERMASSTE RADIIEN NOT DIMENSIONED RADIUS R5 | MATERIAL | ERP NUMBER | - |  Almatec AG Industriestrasse 12 CH-6170 Schüpfheim Switzerland | ALM-ANK1608060 1600H x 800W x 600D DOUBLE WALL ELECTRICAL CABINET | |
| - | - | - | - | KANTEN GEBROCHEN SHARP EDGES REMOVED 0.2...0.4 | GEW./MASS 282.278 kg | ERP RAW NR. | - | | SIZE | ALMATEC IDENT NUMBER |
| - | - | - | - | DREHMOMENT NACH TORQUE ACCORDING TO AAW_0002 | FINISH ACCORDING TO AAW_0005 | UNLESS OTHERWISE SPECIFIED DIMENSIONS EXPRESSED IN METRIC | DATE | A3 | 1585524 | - |
| - | - | - | - | GENERAL TOLERANCES / ALLGEMEINTOLERANZEN ISO 2768 - m L |  | APPROVALS | 20.06.24 | SCALE | RELEASE STATUS | SHEET |
| - | - | - | - | WELD SYMBOLS / SCHWEISSYMBOLLE EN 22553 | | CHECKED & RELEASED | - | 1:13 | Wird bearbeitet | 3/3 |

THIS DRAWING AND THE DESIGN SHOWN HERE ON ARE THE EXCLUSIVE PROPERTY OF ALMATEC SWITZERLAND. ITS CONTENTS CANNOT BE COPIED, COMMUNICATED OR REPRODUCED IN ANY FORM, FOR ANY PURPOSE, WITHOUT PRIOR SPECIFIC WRITTEN CONSENT FROM ALMATEC SWITZERLAND.
 DIESE ZEICHNUNG UND IHR INHALT STEHEN UNTER DEM ALLEINIGEN RECHT DER FIRMA ALMATEC SWITZERLAND. DIE ZEICHNUNG UND IHR INHALT DÜRFEN IN KEINER FORM KOPIERT, WEITERGEGEBEN, ODER REPRODUZIERT WERDEN, OHNE DIE SCHRIFTLICHE ZUSTIMMUNG DER FIRMA ALMATEC SWITZERLAND.